



Motion Control Systems

High-Performance

Pan-Tilt Unit

MODEL: PTU-D47

VERSION: 4.20

REVISION DATE: November, 2011

User Manual

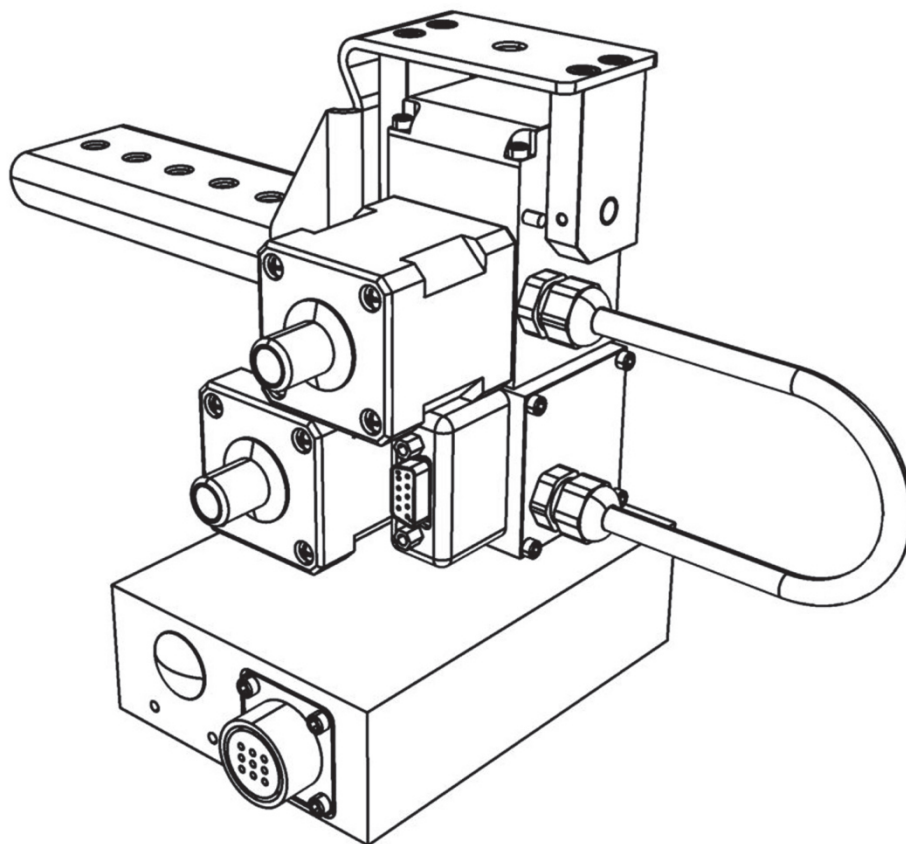

DOCUMENT CONTROL

Date	Author	Rev. #	Changes
10/2010	A. Hernandez	4.00	Initial doc release with new branding
11/2011	A. Hernandez	4.20	Minor updates & errata



Note: This manual describes the PTU-D47 only. If you have any other series of PTU-D47, please refer to the appropriate documentation for that series.

COPYRIGHT NOTICE

Pan-Tilt Unit (Model PTU-D47) User's Manual

©1991, 2011 by FLIR Motion Control Systems, Inc., 890C Cowan Road, Burlingame, California 94010, (650)692-3900, FAX: (650)692-3930, www.FLIR.com./MCS

All rights reserved. Protected under numerous U.S. patents, including 5463432 and 5802412 with other patents pending. No part of this book may be reproduced, stored in a retrieval system, or transcribed in any form or by any means including but not limited to electronic, mechanical, photocopying, recording, or otherwise, without the prior written permission of FLIR Motion Control Systems, Inc.

The information in this manual is subject to change without notice and, except for the warranty, does not represent a commitment on the part of FLIR Motion Control Systems, Inc. FLIR Motion Control Systems, Inc. cannot be held liable for any mistakes in this manual and reserves the right to make changes.

Table of Contents

1	- Introduction	1
1.1	- PTU-D47 Features	1
1.2	- Applications	2
1.3	- About This Manual.....	2
1.3.1	- Formatting Conventions.....	2
1.4	- Models	3
1.5	- PTU-D47 Package Contents	4
1.6	- Related Documentation.....	5
1.7	- Additional Resources	5
1.8	- Technical Support	5
2	- Safety	7
2.1	- Safety Warnings and Cautions.....	7
3	- Quick Start.....	9
3.1	- System Overview	9
3.2	- Installation Components	10
3.3	- Basic Setup.....	10
3.4	- Serial Connection.....	11
4	- Installation and Setup.....	13
4.1	- Mounting the Unit	13
4.2	- Wiring and Connectors	13
4.2.1	- Mechanical Overview.....	13
4.2.2	- Wiring.....	14
4.3	- Power Sources	14
4.4	- Fusing.....	14
4.5	- Shielding.....	14
4.6	- Interface and Host Settings	15
4.6.1	- RS-232 Electrical Connection	15
4.6.2	- RS-485 Electrical Connection	15
4.7	- Initial Power-Up and Test	16
4.8	- Payload Mounting.....	17
4.8.1	- Payload Attachment.....	17
4.9	- Payload Wiring (Optional)	18
5	- Configuring & Programming	19
5.1	- Range of Motion	19
5.1.1	- Default Limits	20
5.2	- Resolution and Step Modes.....	20
5.3	- User-Programmable Settings.....	20

5.3.1 – High-Speed Operation.....	21
5.3.2 – Heavy-Payload Operation	21
5.3.3 – Battery Powered Operation	22
A. – Electrical Specifications	23
A.1 – 19-Pin Connector	24
A.2 - Flying Leads	24
A.3 – 19-Pin Breakout Cable	25
B. – Mechanical Drawings.....	26
B.1 – Payload Mounting Pattern.....	27
B.2 – PTU-D47 Dimensions	28
C. – Networking.....	29
C.1 – Serial Networking Connections.....	29
C.2 – ASCII Command Syntax	30
D. –Troubleshooting	32
D.1 – Mechanical.....	32
D.2 – Power	32
D.3 – Networking	32
D.4 – Technical Support	33
E. – Regulatory Information	35
Class A	35
FCC Notice.....	35
CE Notice	35

Table of Figures

Figure 1: Pan-Tilt System Overview.....	9
Figure 2: PTU Network Configuration.....	29

This page intentionally left blank.

1 - Introduction

The PTU-D47 Pan-Tilt Unit (PTU-D47) from FLIR Motion Control Systems provides fast, accurate, and low-cost positioning of cameras, antennas, lasers, and other payloads. This User Manual contains setup, general configuration, wiring, and mechanical interface information that is intended for use by design engineers and integrators who are configuring, installing, and programming the PTU-D47. Please see www.flir.com/mcs for other documents related to the PTU-D47.



Note: This manual describes setting up and using the PTU-D47 unit. Optional modules are not included in these instructions. If your PTU-D47 includes any optional modules, please refer to the documentation included with those modules.

1.1 – PTU-D47 Features

The PTU-D47 series offers the following features:

- Serial communication capability via terminal or computer
- Small form factor
- Integrated controller
- Payload capacity of over 12lbs
- Pan speeds of over 300° per second and tilt speeds of over 60° per second
- Pan resolution of 0.0514° and tilt resolution of 0.0129° (half-step mode)
- Precise position, speed & acceleration control
- On-the-fly position and speed changes
- Self-calibration on reset
- Host-controllable power consumption
- Simple ASCII command mode
- High-speed binary command interface
- Constant-current motor drives for increased performance and control
- Unregulated 12-30 VDC power input
- Pass-through wiring for payload cable management (optional)
- Electrical compatibility with other FLIR PTU models.

Please refer to the *PTU-D47 Product Datasheet* for complete specifications.

1.2 – Applications

The PTU-D47 is well suited for the following applications:

- Robotics and computer vision
- Webcams
- Thermal and IR cameras
- Teleconferencing
- Advanced monitoring systems
- Tracking
- Photography, videography, and special effects
- Mid- and long-range surveillance systems
- Automated detection and tracking
- Marine/shipboard sensor systems
- Border security & law enforcement
- Highway & transportation monitoring
- Military special operations
- Satellite communications systems
- Microwave antenna systems (passive, active)

1.3 – About This Manual

This section describes the formatting conventions and information contained in this manual.

1.3.1 – Formatting Conventions

This manual uses several formatting conventions to present information of special importance.

Lists of items, points to consider, or procedures that do not need to be performed in a specific order appear in bullet format:

- Item 1
- Item 2

Procedures that must be followed in a specific order appear in numbered steps:

1. Perform this step first.
2. Perform this step second.

Specific keyboard keys are depicted in square brackets and are capitalized, for example: [ESC]. If more than one key should be pressed simultaneously, the notation will appear as [KEY1]+[KEY 2], for example [ALT]+[F4].

Interface elements such as document titles, fields, windows, tabs, buttons, commands, options, and icons appear in **bold** text.

Menus and submenus have the notation **Menu>Submenu**. For example, “Select **File>Save**” means that you should first open the **File** menu, and then select the **Save** option.

Specific commands appear in standard `Courier` font. Sequences of commands appear in the order in which you should execute them and include horizontal or vertical spaces between commands.

This manual also contains important safety information and instructions in specially formatted callouts with accompanying graphic symbols:



WARNING: WARNINGS ALERT YOU TO THE POSSIBILITY OF PERSONAL INJURY OR DEATH IF THESE INSTRUCTIONS ARE NOT FOLLOWED.



CAUTION: CAUTIONS ALERT YOU TO THE POSSIBILITY OF EQUIPMENT OR PROPERTY DAMAGE IF THESE INSTRUCTIONS ARE NOT FOLLOWED.



Note: Notes provide helpful information.

1.4 – Models

Each PTU-D47 unit includes a model number that is located on the base of the unit. This number lists the options present on that particular unit. Different options may require specialized instructions, and this manual will refer to this section where necessary to ensure that you are following the appropriate directions.

The PTU-D47 model number appears as follows:

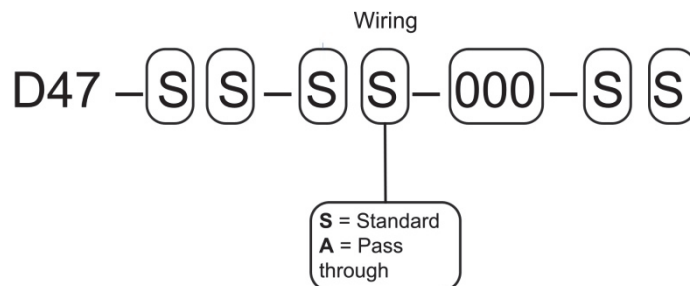

1.5 – PTU-D47 Package Contents

Your PTU-D47 package includes the following items:

- PTU-D47 unit
- Pan-Tilt break-out cable (PTU-CAB-25BO) – Optional
- AC/DC power supply (PTU-APS-30V) – Optional
- RS-232 to RS-485 converter (PTU-CONV-RS485C) – Optional
- *PTU-D47 User's Manual* (this document)
- *Pan-Tilt Command Reference Manual*

1.6 – Related Documentation

The following additional documentation is available for your PTU-D47 unit:

- *PTU-D47 Configuration Guide*: options and accessories ordering guide
- *PTU-D47 Product Datasheet*: product specifications
- *Pan-Tilt Command Reference Manual*: command instructions

1.7 – Additional Resources

FLIR Motion Control Systems, Inc. also maintains a technical support Web site with additional resources for customers in the Support section at www.FLIR.com/MCS. Resources include electronic copies of user manuals, firmware downloads, 3D CAD models, technical notes, and other information.

1.8 – Technical Support

FLIR Motion Control Systems, Inc. provides a range of technical support options:

- **Email:** MCS-support@FLIR.com
- **Web:** www.FLIR.com/MCS
- **Phone:** (650)692-3900, then select “Technical Support”

The preferred method of contacting Technical Support is via email, which helps ensure proper dispatching and tracking to address your questions promptly.

When contacting Technical Support, please provide the following information:

- PTU model and configuration
- Payload (Please include photos, if possible.)
- Parameter settings
- Description of issue/symptoms

This page intentionally left blank.

2 – Safety

This chapter contains important safety instructions. You must read, understand, and comply with all of these safety instructions in order to protect both persons and property. The benefits of a safe installation include increased usability, reliability, and reduced damage to the PTU, payload, and/or other property.

2.1 – Safety Warnings and Cautions

- PTU-D47 installation and setup should be only be performed by qualified personnel.
- The installation must comply with all applicable codes (such as building codes, marine safety codes, etc.).
- The installation must be free of obstructions throughout the entire range of pan-tilt motion. When planning the installation, make sure to take the payload into account to ensure that the PTU-D47 and payload remain unobstructed at all times.
- All mounting methods and materials must be capable of supporting at least four times the combined weight of the PTU-D47, mounted payloads, and cabling.
- Corrosion-resistant hardware (such as stainless steel screws) must be used for all outdoor installations.
- Do not install the PTU-D47 in any location that exceeds the PTU-D47's environmental specifications or near any heat sources such as radiators, heating registers, stoves, etc.
- Always incorporate a readily accessible power disconnect into the installation wiring. (See Sections 3.4 and 3.5.)
- Removing power by disconnecting the power cable or cable harness is not recommended and can result in damage to the system.
- All service procedures must be performed by qualified service personnel in accordance with all applicable instructions.
- If the PTU-D47 is damaged, immediately remove power and contact FLIR Motion Control Systems, Inc.
- Only use replacement parts recommended by FLIR Motion Control Systems, Inc.
- Use caution when lifting the PTU-D47 and/or payload.
- Keep all persons and objects well away from the PTU-D47's panning and tilting radius with payload installed.
- Do not touch or otherwise handle the PTU-D47 while in motion or if there is a possibility of motion. Always remove power before servicing the PTU-D47 and/or payload.

This page intentionally left blank.

3 – Quick Start

The PTU-D47 provides direct serial control for all motions. You may also use a joystick or proprietary controller.

This chapter helps you power up your PTU-D47 and test direct communications from a host computer.



CAUTION: WHEN MOVING THE PAN-TILT AXES WHILE THE PTU IS POWERED DOWN, ALWAYS USE THE KNOBS MOUNTED ON THE PTU MOTORS. MANUAL ROTATION OF THE PAN-TILT AXES (BACK-DRIVING) CAN DEGRADE PTU PERFORMANCE AND ACCURACY.

3.1 – System Overview

The PTU-D47 includes an integrated controller that can be accessed from any host computer over a serial (RS-232 or RS-485) connection. The basic connections are:

- DC power
- Pan-tilt control via RS232/485 serial connection

When ordered with the payload wiring option, the PTU-D47 allows you to use a single connector at the base of the PTU-D47 for payload signals such as payload power, video, etc.

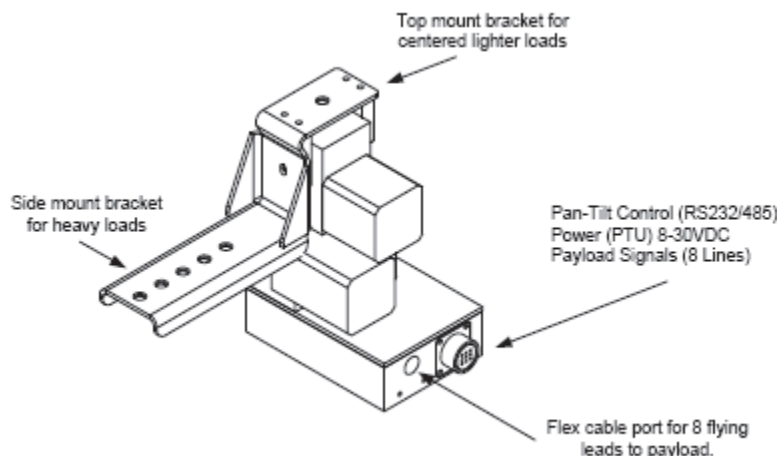

Figure 1: Pan-Tilt System Overview.

You may control the PTU-D47 from any host computer using the built-in ASCII protocol described in the included *Pan-Tilt Command Reference Manual*. The PTU-D47 also supports a binary protocol via a C Programmers Interface (PTU-CPI) for high speed, hard real-time controls such as tracking. Drivers are also available using third-party software packages such as LabVIEW and digital video control systems.

3.2 – Installation Components

A complete PTU-D47 system configuration requires the following components:

- PTU-D47 unit
- *PTU-D47 User's Manual* (this document)
- *Pan-Tilt Command Reference Manual*
- Breakout cable (PTU-CAB-25BO) – Optional
- RS-232 to RS-485 converter (PTU-CONV-RS485C) – Optional
- AC/DC power supply (PTU-APS-30V) – Optional

3.3 – Basic Setup

To perform a basic PTU-D47 setup and installation:

1. Mount the PTU-D47 securely to a lab bench, tripod, or other stable platform. Verify that there is enough clearance around the unit. See Section 4.1 for detailed mounting instructions.
2. Attach either the optional breakout cable or customer-supplied cable to the 19-pin connector at the base of the PTU-D47 by inserting the connector as keyed and then twisting to secure the connection.



CAUTION: DISCONNECTING THE CABLE WHILE THE PTU-D47 IS POWERED ON CAN DAMAGE THE UNIT. ALWAYS POWER DOWN THE PTU-D47 BEFORE DISCONNECTING THE CABLE.

3. Establish serial wiring to the PTU-D47 as appropriate for your needs, as described below.
4. Power on and test the PTU-D47.

3.4 – Serial Connection

To connect, power on, and test the PTU-D47 using the serial interface:

1. Decide whether to use the RS-232 or RS-485 serial connection.
 - If RS-232, skip to Step 3.
 - If RS-485, proceed to Step 2.
2. Connect the PTU-D47 as follows:
 - Attach the DB25 to DB9 converter on one side of the RS-232 to RS-485 converter.
 - Attach one end of the four-pin RJ-11 phone cable to the other side of the RS-232 to RS-485 adapter.
 - Set the switches on the RS-232 to RS-485 converter to **T-RTS RxON** and **DCE**.
 - Attach the four-pin RJ-11 female-to-female adapter to the other end of the phone cable. This is important because the adapter rearranges the pins; the PTU-D47 will not function if the adapter is not attached correctly.
 - Connect the RS-485 connector from the breakout cable into the adapter.
 - Provide power to the converter through the included power supply.
3. Attach a standard RS-232 cable between a host PC and the DB9F connector on the PTU-D47 labeled RS-232.
4. Open a terminal program such as HyperTerminal® or TeraTerm®.

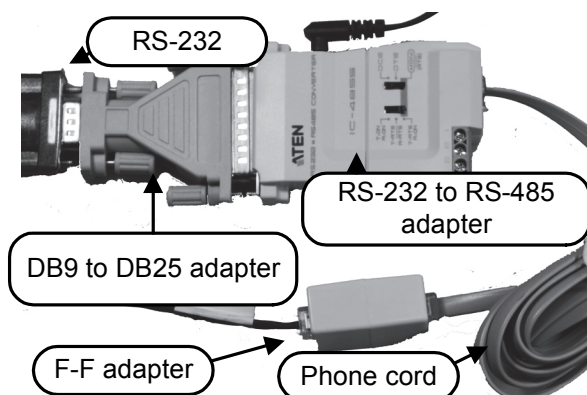

Note: HyperTerminal is available with Microsoft® Windows XP® and previous versions. You may download TeraTerm from <http://tssh2.sourceforge.jp/>.

5. Create a new connection with the following communications parameters:
 - 9600 baud
 - 8 data bits
 - 1 stop bit
 - no parity
 - no handshaking
6. Provide DC power to the PTU-D47. The factory cable (part number PTU-CAB-25BO) allows easy plug-in power from the factory AC/DC power supply model PTU-APS-30V. Alternatively, you may provide your own DC power source if appropriate, as described in Section 4.3.

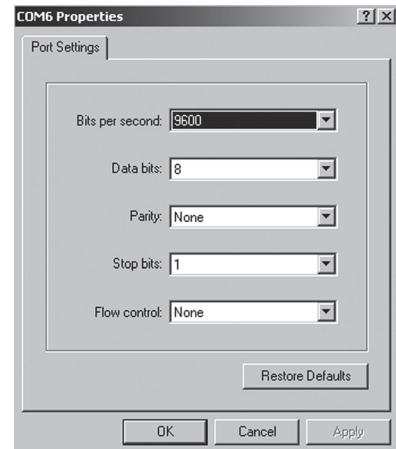

CAUTION: USE AN APPROPRIATELY RATED POWER STRIP WITH SURGE PROTECTION TO ALLOW SAFE POWER REMOVAL WHEN YOU ARE READY TO POWER DOWN.

7. Power on the PTU-D47 by turning on the switch on the power strip. If power is working, the unit will begin a self-calibration and text will appear on your terminal identifying the unit's configuration.
8. Test pan-tilt operation by typing commands into your terminal program. The following command sequence will familiarize you with basic PTU-D47 operation:

```
pp2500 *      tp-900 *  PS1900 *  pp0 *
```

This sequence:
 - sets the pan axis to position 2500
 - sets the tilt axis to position -900
 - sets the pan speed to 1900 positions per second, and
 - sets the pan position back home.
9. Power down the PTU-D47 by turning off the switch on the power strip.
10. Mount and wire your payload (e.g. camera) on the PTU-D47, as described in Sections 4.8 and 4.9.

The *Pan-Tilt Command Reference Manual* contains complete command interface instructions.

4 – Installation and Setup

This section describes proper mechanical and electrical PTU-D47 installation.

4.1 – Mounting the Unit

The basic mounting pattern uses two #1/4-20 socket-head cap screws. Both mounting screws must be used, and mount must be strong enough to support the combined load of the PTU-D47 unit, payload, and additional forces exerted on the system (such as wind, G forces, etc.). A good rule of thumb is that the mount must be capable of supporting at least four times the combined weight of the PTU-D47 and payload. For example, a mount for a PTU-D47 with a 10 lb. payload must be able to support at least 40 lbs.



WARNING: FAILURE TO USE BOTH MOUNTING SCREWS AND/OR TO SECURE THE PTU-D47 AND ITS PAYLOAD TO A SUFFICIENTLY STRONG MOUNTING CAN CAUSE THE INSTALLATION TO FAIL. THIS CAN RESULT IN PERSONAL INJURY OR DEATH, AND/OR DAMAGE TO THE PTU-D47 UNIT AND/OR PAYLOAD.

4.2 – Wiring and Connectors

The standard PTU-D47 has a base connector and may also have a cable with flying leads that can connect to the payload terminal block or custom connector. Please refer to Appendix A for detailed pin-out and connector requirements.

4.2.1 – Mechanical Overview

The base of the PTU-D47 houses the 19-pin base receptacle that complies with MIL standard MIL-C-26482. Basic control requires connecting a DC power source and a host PC to the PTU-D47. The supplied breakout cable and power supply allow you to have your PTU-D47 plugged in and running within minutes. Appendix A contains specific pin outs and wiring diagrams; if needed, you may use this information to make custom cables to suit your specific installation requirements. Please refer to Section 3 for basic connection and power-on instructions.

The PTU-D47 also provides optional payload pass-through signals that connect between pins in the base receptacle to corresponding payload wires (flying leads).

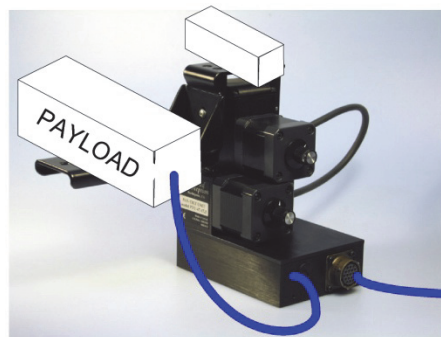

Pan-Tilt Control (RS-232/485)
Power (PTU) 8-30VDC
Payload Signals (8)



CAUTION: ALWAYS FOLLOW ALL APPLICABLE SPECIFICATIONS (INCLUDING BUT NOT LIMITED TO MAXIMUM VOLTAGE AND CURRENT) WHEN ATTACHING PAYLOAD SIGNALS TO THE SYSTEM.

4.2.2 – Wiring

The PTU-D47 is offered with wiring that provides an alternate RS-232 communication option for communicating with the PTU-D47 in addition to the RS-485 lines, and includes a total of 9 payload pass-through lines that provide:

- 2 video channels (3C)
- 1 power circuit (3C)
- 3 general I/O lines (3C).

4.3 – Power Sources

The PTU-D47 requires an unregulated 12-30VDC power source capable of 48 continuous peak watts.

- For maximum PTU-D47 performance, use the highest motor voltage within the allowable range.
- For the quietest and smoothest PTU-D47 operation, you can use a lower motor voltage, such as 24VDC.

The PTU-D47 pan-tilt maximum speed depends on the input voltage. 30 VDC provides the highest maximum speed; lower voltages will reduce the maximum achievable speed.



CAUTION: THE PTU-D47 CONTAINS OVER-VOLTAGE AND OVERCURRENT PROTECTION; HOWEVER, SUSTAINED OVERLOAD CAN DAMAGE THE UNIT.

4.4 – Fusing

If you are using a DC power source that is capable of supplying current beyond the PTU-D47 rated maximums, you must add an appropriate fuse in series with the DC power source. For example, you must fuse a connection made to a vehicle battery or lighter plug.



WARNING: FAILURE TO PROPERLY FUSE THE PTU-D47 POWER SOURCE COULD OVERLOAD INTERNAL PROTECTION DEVICES AND CAUSE DEATH, PERSONAL INJURY, AND/OR DAMAGE TO THE UNIT.

4.5 – Shielding

Shielding protects the PTU-D47 from external Electromagnetic Interference (EMI) and prevents radiation emission from internal and external cabling. Proper shielding must be used to meet the regulatory requirements described in Appendix E. All PTU-D47 wiring configurations provide a shield pin at both the base and the payload, as described in Appendix A. This shield is also

attached to the PTU-D47 housing. The shield pin is not connected to ground internally. The shield potential will vary from ground and must not be confused with a ground pin.

Ideally, either the PTU-D47 chassis or the shield pin at the base connector should be routed to a long grounding rod that is embedded in the ground. If needed, it is also acceptable to route the shield pin to the power ground through a surge protection device.



CAUTION: THE PTU-D47 WILL NOT BE PROPERLY SHIELDED UNTIL THE SHIELD PIN IS PROPERLY CONNECTED.

4.6 – Interface and Host Settings

The PTU-D47 includes either RS-232 or RS-485 communications.

4.6.1 – RS-232 Electrical Connection

RS-232 communications have the following connections:

- **TxD:** Pin 2 (carries data from the PTU-D47)
- **RxD:** Pin 3 (carries data to the PTU-D47)
- **GND:** Pin 5



Note: TxD and RxD assignments can vary depending on your host computer. If your initial connection does not work, try using a null modem.

Serial communication between the PTU-D47 and your host computer should be set as follows:

- **Baud rate:** 9600. You may adjust the baud rate using software commands. Please refer to the *Pan-Tilt Command Reference Manual* for instructions.
- **Start bit:** 1
- **Data bits:** 8
- **Stop bit:** 1
- **Handshaking:** off
- **XON/XOFF:** not used

4.6.2 – RS-485 Electrical Connection

RS-485 communications have the following connections:

- **Duplex:** full
- **Connections:** Tx+, Tx-, Rx+, and Rx-
- **Voltage:** RS-422 or RS-485 levels

Serial communication between the PTU-D47 and your host computer should be set as follows:

- **Baud rate:** 9600. You may adjust the baud rate using software commands. Please refer to the *Pan-Tilt Command Reference Manual* for instructions.
- **Start bit:** 1
- **Data bits:** 8
- **Stop bit:** 1
- **Handshaking:** off
- **XON/XOFF:** not used

4.7 – Initial Power-Up and Test

This section describes how to power up and test your PTU-D47 using the serial interface. Test and verify all cable connections and connector wiring before power-up.



Note: Complete the initial installation and testing, then exercise the PTU-D47 and familiarize yourself with its operations and commands before mounting your payload (such as a camera).

To test the PTU-D47:

1. Configure the RS-232 or RS-485 port on the host computer as described in Section 3.5.
2. Power up the PTU-D47. A boot message will appear on your terminal screen and the unit will begin a reset cycle. An asterisk (*) appears on your screen when the reset cycle is finished. If the PTU-D47 did not reset properly, please refer to the troubleshooting instructions below.
3. Please see the *Pan-Tilt Command Reference Manual* for a complete list of commands and associated parameters and other usage instructions.

4.8 – Payload Mounting

The PTU-D47 payload bracket system can support a variety of payloads including cameras, lasers, antennas, and other equipment. Figure 3 shows the PTU-D47 bracket configuration.



WARNING: FAILURE TO FOLLOW ALL PAYLOAD MOUNTING INSTRUCTIONS COULD RESULT IN A STRUCTURAL FAILURE THAT MAY RESULT IN DEATH, PERSONAL INJURY, AND/OR DAMAGE TO THE UNIT.

The following guidelines apply to all payload mounts:

- The maximum payload mounting screw size is ¼”.
- Always use washers, lock washers, etc. as appropriate.
- If the PTU-D47 is being mounted in an outdoor location, use corrosion-resistant hardware (such as stainless steel).
- Apply thread locking compound to all screws, such as Loctite® 242.

4.8.1– Payload Attachment

The following guidelines apply to all payload attachments:

- Mount all payloads as close to the PTU-D47 as possible. This minimizes the distance between the payload Center of Gravity (CG) and the center of rotation of the axes, which reduces stress on the PTU-D47 unit and mounting. It also improves performance by reducing the amount of torque required to move the payload.
- Verify that the payload will clear the PTU-D47 housing and all surrounding objects throughout the entire range of motion.
- The PTU-D47 is rated for a maximum load of 12 lbs; however, load distribution affects the actual weight that the PTU-D47 can safely move. The amount of torque needed to move a payload depends on a number of factors such as payload weight, distance from the payload CG to the center of rotation, acceleration and speed settings, power levels, environmental factors, etc.
- The PTU-D47 allows full control over acceleration, speed, and power levels. Mount your payload and configure these parameters appropriately to ensure reliable operation.

To attach and test your payload:

1. Mount your payload. Side mounting is preferable for heavy loads because this keeps the payload CG closer to the tilt axis, thereby minimizing torque requirements.
2. Verify that the payload is securely attached to the payload bracket.
3. Move the PTU-D47 tilt axis through its entire range to test its ability to carry the load.



CAUTION: THE CG OF TOP-MOUNTED PAYLOADS IS FURTHER FROM THE TILT AXIS AND MAY REQUIRE MORE TORQUE THAN A SIMILAR SIDE-MOUNTED PAYLOAD.

- Using the terminal interface, enter `TN TX` to query the tilt minimum and maximum limits, then enter `TP<min> A TP<max>` to cycle the PTU-D47 through its entire tilt range (where `<min>` is the number returned by the `TN` query and `<max>` is the number returned by the `TX` query). If needed, enter `H` to stop the PTU-D47 immediately.

If the load is too heavy or moving too quickly, the PTU-D47 will lose synchronization, which will be audible as a grinding sound from the PTU-D47 motors. Stop the test immediately if this occurs, and refer to Sections 5.3.2 and 5.3.3. This does not damage the PTU-D47 but does indicate that the payload is not mounted and/or the PTU-D47 is not configured correctly to move the payload.



Note: Please refer to Section 5.3.2 for more information on configuring the PTU-D47 for heavier payloads.



CAUTION: DO NOT PROCEED BEYOND THIS STEP UNLESS AND UNTIL THE PTU-D47 PASSES THE TILT AXIS MOTION TEST.

4. Move the PTU-D47 pan axis through its entire range to test its ability to carry the load. Enter `PN PX` to query the pan minimum and maximum limits, then enter `PP<min> A PP<max>` to cycle the PTU-D47 through its entire tilt range (where `<min>` is the number returned by the `PN` query and `<max>` is the number returned by the `PX` query). If needed, enter `H` to stop the PTU-D47 immediately.



WARNING: STOP THE PTU-D47 IMMEDIATELY BY ISSUING AN H COMMAND (SERIAL INTERFACE) IF THE PAYLOAD IS ABOUT TO COLLIDE WITH THE PTU-D47 AND/OR ANOTHER OBSTACLE. A COLLISION COULD CAUSE A STRUCTURAL FAILURE THAT MAY RESULT IN INJURY OR DEATH.

If the load is too heavy or moving too quickly, the PTU-D47 will lose synchronization, which will be audible as a grinding sound from the PTU-D47 motors. Stop the test immediately if this occurs, and refer to Sections 5.3.2 and 5.3.3.

5. If the PTU-D47 passes the above pan and tilt axis load handling tests, you are ready to begin controlling your payload using the commands described in the *Pan-Tilt Command Reference Manual*.

4.9 – Payload Wiring (Optional)

The PTU-D47 provides payload pass-through signals that connect between pins in the base receptacle to flying leads that can be connected to the payload terminal block or custom connections. Appendix A.2 displays the pin-out.



CAUTION: FOLLOW ALL APPLICABLE SPECIFICATIONS FOR PASS-THROUGH SIGNALS, SUCH AS MAXIMUM VOLTAGE AND CURRENT LEVELS.

5 – Configuring & Programming

This chapter describes how to configure and program your PTU-D47.

Follow the appropriate instructions to connect the PTU-D47 to the host computer, power it on, and access it as described in Section 3.5.

5.1 – Range of Motion

The PTU-D47 range of motion can be limited in the following ways:

- **Hard:** A hard limit physically cannot be exceeded. For example, PTU-D47 units cannot pan across all 360°, and units with top-mounted payloads may have smaller tilt limits than units with side-mounted payloads. A physical pin on the PTU impedes movement.

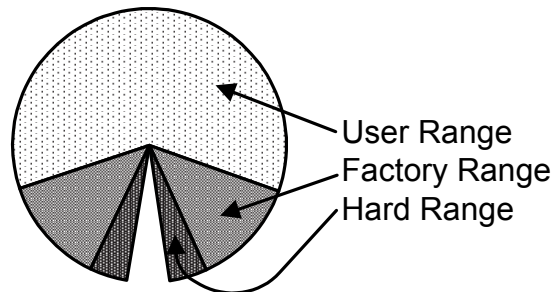

**Non-Overlapping,
Non-Continuous
Range of Motion**

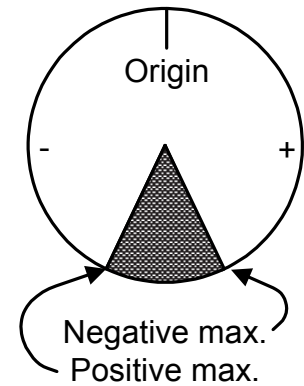

**Overlapping
Range of Motion**

- **Factory:** Factory limits are smaller than hard limits to prevent physical damage to the PTU-D47 and/or payload. These limits may be exceeded in certain circumstances, such as disabling pan limits.
- **User:** Soft limits are programmable limits that are smaller than hard limits and can be as large as factory limits. The PTU-D47 does not retain lost limits after power is cycled off and back on.

The PTU-D47 uses high-precision optical limit sensors that allow faster reset sequences and user-programmable ranges. It can also be equipped with optional mechanical stops that will limit pan/tilt motion to preset limits. It is possible to set these stops to allow overlapping limits, as shown in the image on the previous page.



Note: If needed for your application, order optional mechanical stops with your PTU-D47 because they are installed during manufacturing.

5.1.1 – Default Limits

In the following image:

- The positive pan axis direction is counterclockwise when looking down at the top of the PTU-D47.
- The positive tilt axis direction is clockwise when looking sideways at the PTU-D47 with the motors and connectors facing to the right.



Note: The pan axis limits are +/- 159° (+/-180° with limits disabled). The default tilt axis limits are +31° and -47°.

5.2 – Resolution and Step Modes

The PTU-D47 uses stepper motors that drive the unit through a gear reduction system. The internal controller allows stepper motor control in manual (1/2, 1/4, and 1/8) or automatic step modes. The following table lists the pan and tilt axis resolution in degrees.

	1/2 STEP	1/4 STEP	1/8 STEP
PAN AXIS	0.052°	0.026°	0.013°
TILT AXIS	0.013°	0.006°	0.003°



Note: Larger step modes increase torque and maximum speed vs. smaller step modes. The PTU-D47 includes an automatic stepping mode (auto-step) that optimizes this tradeoff for many applications. You may command the PTU-D47 in 1/8 steps when in automatic stepping mode.

5.3 – User-Programmable Settings

The PTU-D47 has a number of user-programmable parameters that can significantly affect performance for a given payload and application. These parameters should be set to values that are appropriate for your payload and application needs. This section provides an overview of how to optimize your PTU-D47 for high-power and/or high-speed operation. Please refer to the *Pan-Tilt Command Reference Manual* for complete instructions.



CAUTION: USE HIGH-SPEED AND/OR HIGH-POWER SETTINGS WITH CARE, PARTICULARLY WHEN MOUNTING A HEAVY AND/OR BULKY PAYLOAD.



WARNING: FAILURE TO ADEQUATELY SECURE THE PTU-D47 TO A MOUNTING THAT CAN WITHSTAND THE FORCES APPLIED BY BOTH HIGH-SPEED, HIGH-POWER MOVEMENT AND ENVIRONMENTAL FACTORS SUCH AS VEHICLE MOVEMENT OR WIND CAN CAUSE A STRUCTURAL FAILURE RESULTING IN INJURY OR DEATH

5.3.1 – High-Speed Operation

The following factors should be considered when planning high speed operation:

- Load weight, weight distribution, and dynamics.
 - Move the payload as close to the axis centers of rotation as possible. Doing this will reduce the torque required to move the payload and allow a higher top speed.
 - Balancing the load, such as by using a counterweight or splitting the payload into two pieces can also help significantly.
- Desired upper speed limit.
- Rate of acceleration.
- The base (start-up) speed.
- Power supply voltage. Higher voltages within the permissible range significantly improve axis speed and acceleration performance.
- In-motion power modes. If the duty cycle is less than 20%, you may use high move power to increase the top speed.
- Multi-axis dynamics. Simultaneously moving the tilt and pan axes affects the forces exerted on the PTU-D47.
- Always begin high-speed tests on each axis in isolation. Only perform simultaneous pan-tilt movements once each individual axis is optimized.
- The base speed is the PTU-D47 minimum speed. In practice, the unit will instantly accelerate to this speed. Setting a base speed can help speed up movement by eliminating a segment of acceleration time.
- Aggressive acceleration settings with heavy payloads can cause increased wear on the PTU-D47.

5.3.2 – Heavy-Payload Operation

If the PTU-D47 fails the initial load handling tests, you may be able to program it for higher-power operations. The speed and acceleration of a mechanical system depend on the inertial properties of the payload. The ability of the PTU-D47 to successfully move the payload without

losing synchronization depends upon the inertial payload factors and their relationship to power supply voltage, unit speed, acceleration, position, motor torque, etc.

To increase payload capacity:

Configure the PTU-D47 for increased motor current and torque. If your move duty cycle is less than 20%, you can use the following serial commands: `PMH` `TMH` `PHR` `THR`.

You may also:

- Move the payload CG closer to the PTU-D47 tilt axis. See Section 4.8.2.
- Use a higher-voltage power source in the permissible range
- Determine if the payload can be modified to lighten it.
- Set the base speed to 57.
- If the PTU-D47 is having trouble resetting the tilt axis, try using user limits to reduce the tilt-axis range of motion.
- Reduce speed and/or acceleration.

Please refer to the *Pan-Tilt Command Reference Manual* for more information.

5.3.3 – Battery Powered Operation

The PTU-D47 can be battery powered. Battery-powered applications must conserve as much power as possible. The PTU-D47 includes commands that control pan-tilt motor power consumption both while moving and when stopped. Please refer to the *Pan-Tilt Command Reference Manual* for more information.



CAUTION: ALWAYS USE A FUSE WHEN CONNECTING THE PTU-D47 TO A BATTERY.

A. – Electrical Specifications

This Appendix describes the PTU-D47 wiring. Please refer to Section 4.2.1 for a mechanical overview.



CAUTION: DO NOT EXCEED MAXIMUM RATED PASS-THROUGH AMPERAGES. FUSE PAYLOADS AT RATED TRIP VALUES. THE PTU-D47 WARRANTY DOES NOT COVER DAMAGE CAUSED BY OVERCURRENT SITUATIONS.



CAUTION: ALWAYS TERMINATE THE SHIELD LINE TO AN APPROPRIATE SYSTEM SHIELD OR GROUND CONNECTION.

In general:

- TX lines carry data from the PTU-D47.
- RX lines carry data to the PTU-D47.

A.1 – 19-Pin Connector

This table displays the PTU-D47 19-pin connector pin assignments.

PIN	ASSIGNMENT
A	RS485_TX-
B	RS485_RX-
C	RS485_RX+
D	PTU_GND
E	PTU_9-30VDC
F	SHIELD
G	VIDEO1_GROUND
H	VIDEO1_SIGNAL
J	RS-232_SGND
K	RS-232_OUT
L	RS-232_IN
M	RS232_GND
N	PT3
P	PT2
R	PAYLOAD -
S	PAYLOAD +
T	VIDEO2_SIGNAL
U	VIDEO2_GROUND
V	PT1

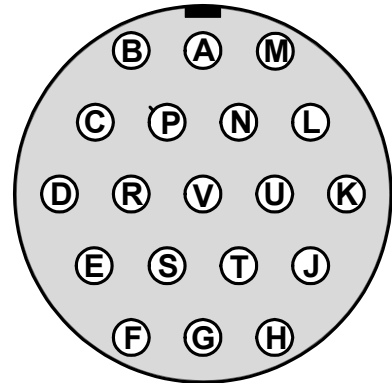

A.2 - Flying Leads

This table displays the flying lead assignments.

LEAD COLOR	PTU-D47 BASE CONNECTOR	FUNCTION
Yellow	T	Video 2 Signal
Blue	H	Video 1 Signal
White	G	Video 1 Shield
Brown	N	Reserved 3
Black	V	Reserved 1
Green	P	Reserved 2
Pink	S	Payload 0-30VDC
Gray	R	Payload Ground
green	F	Shield

A.3 – 19-Pin Breakout Cable

This diagram displays the optional 19-pin breakout cable (PTU-CAB-25BO) wiring and connectors.

19-Pin PTU-D47 Breakout Cable

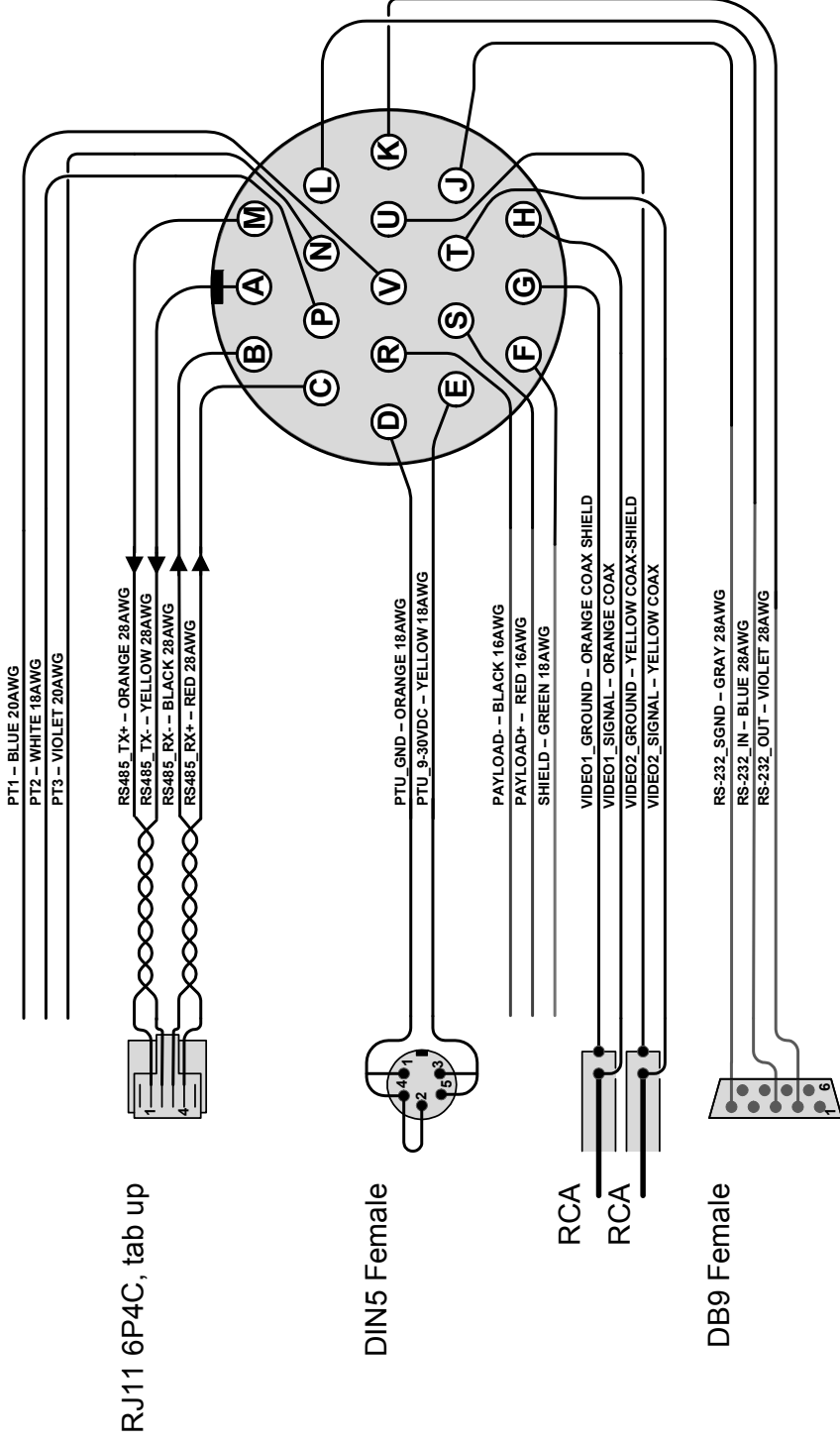

B. – Mechanical Drawings

The PTU-D47 can use side and/or top payload mounting brackets. This Appendix describes the payload mounting patterns for the different brackets and displays the PTU-D47 unit dimensions.

B.1 – Payload Mounting Pattern

The following images display the dimensions and mounting patterns for both the top and side brackets. The holes and bracket positions relative to the hub are identical for all mounting combinations.

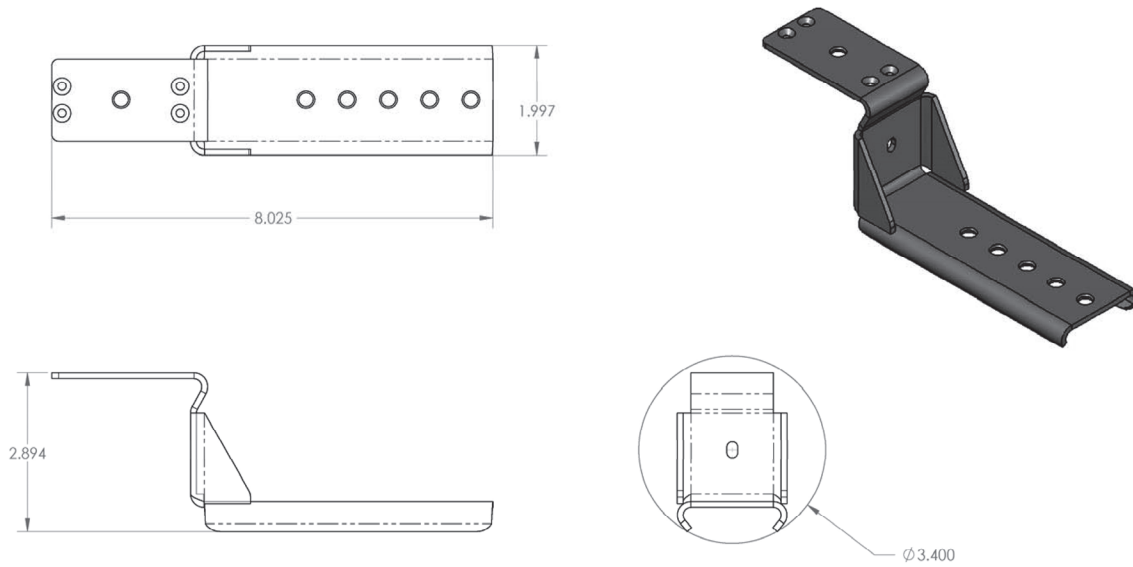

B.2 – PTU-D47 Dimensions

This image displays the standard PTU-D47 dimensions.

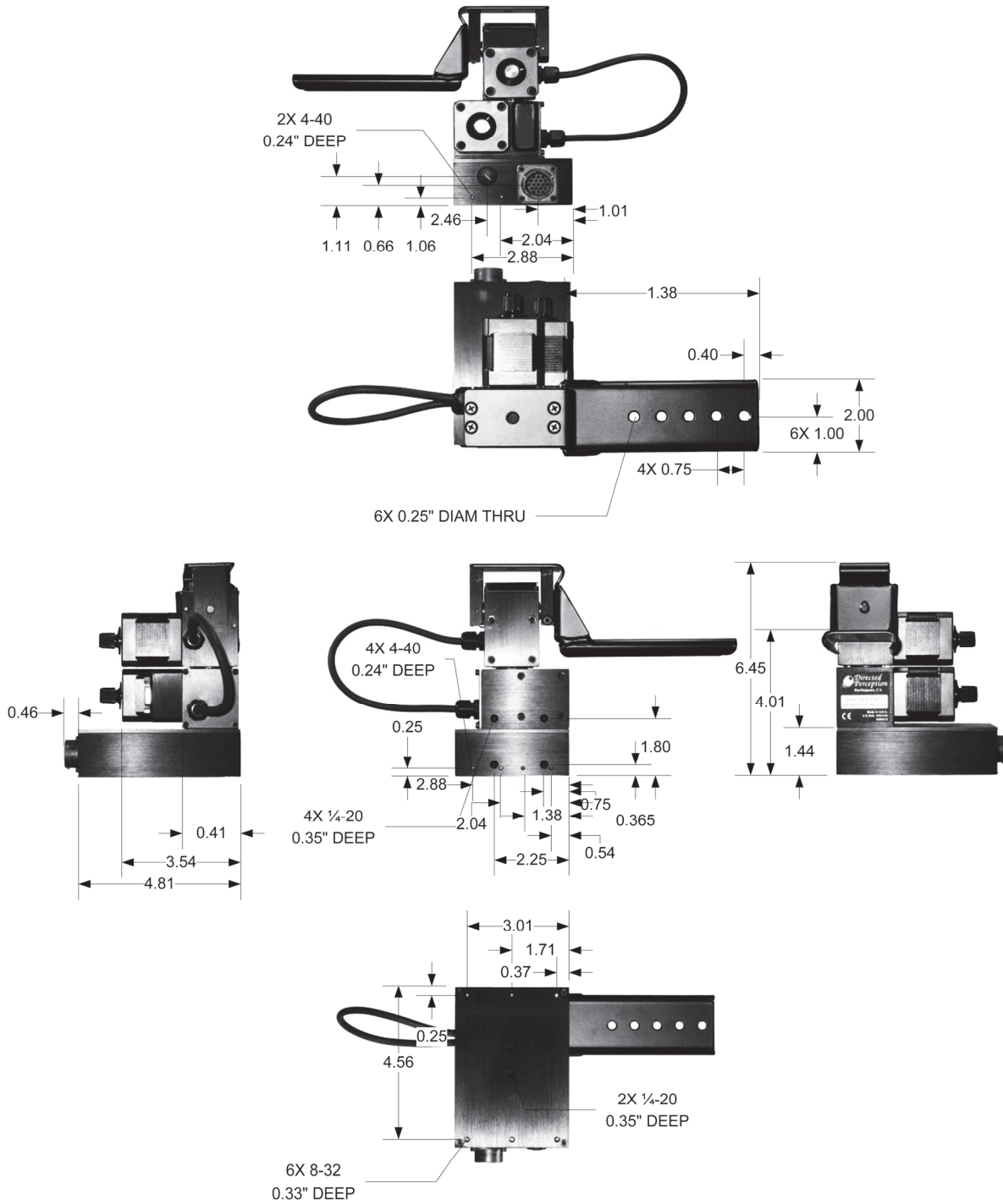

C. – Networking

You may connect up to 127 PTU-D47 units to a single host computer port. The host computer can then address each connected PTU-D47 as if it were the only unit on the network. This makes it easy to migrate code developed for a single PTU-D47 to a network of PTU-D47 units controlled by one host computer.

To connect multiple PTU-D47 units to a single host computer via serial:

1. Assign a unique network ID number to each PTU-D47.
2. Connect the PTU-D47 units and host computer to the serial network.
3. Test the configuration by addressing each PTU-D47 by its unit ID and issuing commands and queries.

C.1 – Serial Networking Connections

Multiple PTU-D47 units can be networked and connected to the host computer's RS-232 port. All network communications use RS-485, meaning that you must have an RS-232 to RS-485 adapter if the host computer does not directly support full-duplex RS-485 I/O. The host computer functions as the network host, meaning that its TX and RX lines define the directions of data traffic flow. Each PTU-D47 on the network is a client that communicates with the host using a full-duplex connection.

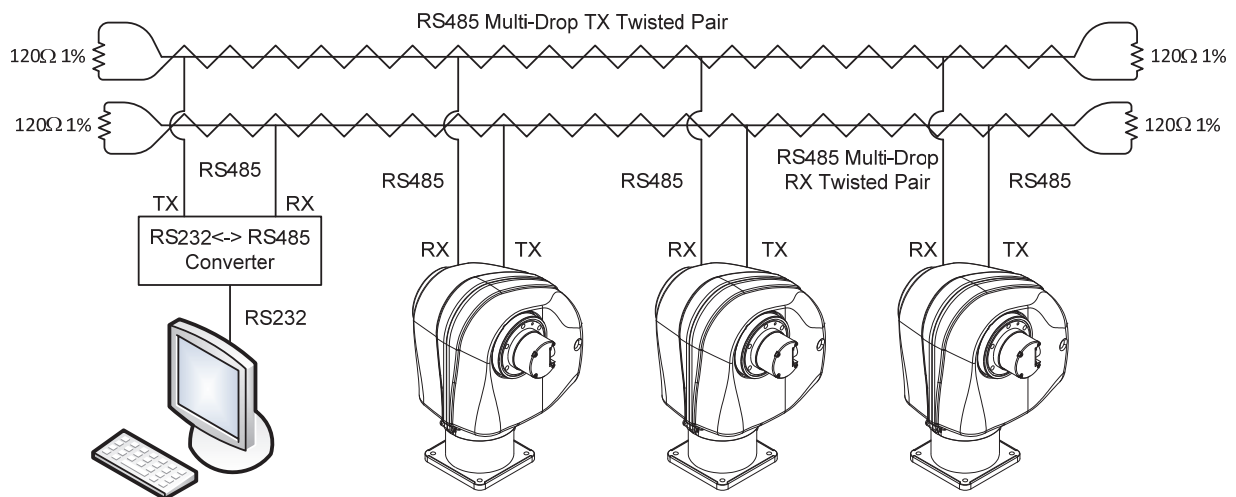

Figure 2: PTU Network Configuration

When making your own data cables, FLIR Motion Control Systems, Inc. recommends using a good quality twisted pair cable with about 100Ω impedance, which provides good noise immunity for RS-485 connections.

The following RS-232 to RS-485 converters are recommended:

- ATEN IC-485S
- Moxa A50

Both adapters require a flipped RJ-12 connector (such as a standard phone cord).

Terminate the serial network by placing 120 Ω 1% resistors between the RS-485 Transmit+/Transmit- (Tx+/Tx-) and Receive+/Receive- (Rx+/Rx-) wires at each end of the network, as shown in Figure 5.

C.2 – ASCII Command Syntax

This section provides a brief overview of the ASCII command syntax. Please refer to the *Pan-Tilt Command Reference Manual* for complete information and instructions.

The PTU-D47 uses both commands and queries. A command tells the PTU-D47 to do something (such as pan to a specific angle). A query asks the PTU-D47 to return the requested value (such as reporting the current pan angle).

The basic ASCII command syntax is `<command><parameter><delimiter>`, where:

- `<command>` is the actual command (such as PP for pan position),
- `<parameter>` is a numerical value (such as the desired pan position), and
- `<delimiter>` is a character used to denote the end of a command. Valid delimiter characters can be either [SPACE] or [ENTER].

The basic ASCII query syntax is `<command><delimiter>`, where:

- `<command>` is the actual command (such as PP for pan position),
- `<delimiter>` is a character used to denote the end of a query. Valid delimiter characters can be either [SPACE] or [ENTER].

For example:

- **Command:** `PP<position><delim>` sets the desired absolute pan position.
- **Query:** `PP<delim>` returns the current absolute pan position.

Commands and queries return results that display on the terminal screen, as follows:

- A successfully executed command displays * on the terminal screen.
- A successfully executed query displays `<QueryResult>` (where `<QueryResult>` is the result of the query you just executed).
- A failed command displays `! <ErrorMessage>` (where `<ErrorMessage>` describes the error encountered).
- A pan axis limit hit asynchronously displays `!P`.
- A tilt axis limit hit asynchronously displays `!T`.

This sample command sequence pans the PTU-D47 to the left, waits, and then pans it back to the right:

```
S
PP-2500 *
A *
PP * Current Pan position is -2500
PP2500 *
A *
PP * Current Pan position is 2500
```

D. – Troubleshooting

This appendix presents common mechanical, power, and networking challenges and resolutions, and also provides information about contacting FLIR MCS Technical Support.

D.1 – Mechanical

After powering on, the PTU-D47 stops moving with a grinding noise.

- If you have a payload attached:
 - The payload may be too heavy. Try moving the payload closer to the center of rotation of the affected axis and/or reducing the payload weight.
 - The movement settings may be too aggressive. Reduce the upper speed limit and/or acceleration.
- If you do not have a payload attached, contact FLIR MCS Technical Support.

D.2 – Power

After powering on, the PTU-D47 stops moving with a grinding noise.

- If you have a payload attached:
 - The payload may be too heavy. Try moving the payload closer to the center of rotation of the affected axis and/or reducing the payload weight.
 - The movement settings may be too aggressive. Reduce the upper speed limit and/or acceleration.
- If you do not have a payload attached, contact FLIR MCS Technical Support.

The PTU-D47 reset movements are different than older PTU-D47 models.

- This is normal behavior.

D.3 – Networking

Unable to establish serial communications with the PTU-D47.

- If you are using RS-232:
 - Try using a null-modem adapter.
 - If you are using a laptop, make sure that it is plugged in. RS-232 will not work if the PTU-D47 and host computer grounds are too far apart.
 - Verify that the RS-232 port is working using a loop-back adapter. If you do not have a loop-back adaptor, connect pins 2 and 3 of the DB-9 RS-232 connector. Any characters

typed into the serial terminal should be echoed back when the loop-back adapter is attached.

- If you are using the RS-232 to RS-485 adapter provided by FLIR Motion Control Systems:
 - Set the switches to **T-RTS RxON** and **DCE**.
 - Make sure the adaptor is powered.
 - Try using a null-modem adaptor
 - If you are using a laptop, make sure that it is plugged in. RS-232 will not work if the PTU-D47 and host computer grounds are too far apart.
 - Verify that the RS-232 port is working using a loop-back adapter. If you do not have a loop-back adaptor, connect pins 2 and 3 of the DB-9 RS-232 connector. Any characters typed into the serial terminal should be echoed back when the loop-back adapter is attached.

D.4 – Technical Support

FLIR Motion Control Systems, Inc. provides a range of technical support options to ensure that your project is a success. To access Technical Support:

- Visit the Support section at www.FLIR.com/MCS.
- Email Technical Support at MCS-support@FLIR.com.
- Call (650)692-3900 and select **Technical Support**.

Email is the preferred method of obtaining support to help ensure proper dispatching and tracking to address your questions promptly. When emailing Technical Support, please provide the following information:

- PTU model and configuration
- Payload information, including photos
- Parameter settings
- Detailed issue/symptom description

This page intentionally left blank.

E. – Regulatory Information

Electromagnetic Interference (EMI) is any signal or emission, either radiated in free space or conducted along power or signal leads, that endangers the function of a radio navigation or other safety service or that seriously degrades, obstructs, or repeatedly interrupts a licensed radio communications service.

Class A

Class A equipment has been tested and found to comply with the limits for a Class A digital device, pursuant to Part 15 of the FCC Rules. These limits are designed to provide reasonable protection against harmful interference in a commercial environment. This equipment generates, uses, and can radiate radio frequency energy and, if not installed and used in accordance with the instructions, may cause harmful interference to radio communications. However, there is no guarantee that interference will not occur in a particular installation. Operation of this equipment in a residential area is likely to cause harmful interference, in which case the user will be required to correct the interference at his/her own expense.

Caution: Changes or modifications of this equipment not expressly approved by manufacturer could result in violation of Part 15 of the Federal Communication Commission's rules. The FCC has prepared the following booklet: "How to Identify and Resolve Radio-TV Interference Problems." It is available from the US Government Printing Office, Washington DC, 20402. Stock Number 004-00-00345-4.

FCC Notice

According to 47CFR, Parts 2 and 15, Subpart B Class A:

This device complies with FCC Part 15, Subpart B Class A of the FCC Rules. Operation is subject to the following two conditions: (1) This device may not cause harmful interference, (2) This device must accept any interference received including interference that may cause undesired operations.

CE Notice

This is a Class A product. In a domestic environment, this product may cause radio interference, in which case the user may be required to take adequate measures.

ABOUT FLIR MOTION CONTROL SYSTEMS

FLIR Motion Control Systems, Inc. (formerly Directed Perception) is a leading manufacturer of innovative devices and software for the intelligent control of sensors and sensor processing. In 1992, FLIR MCS created one of the first miniature computer-controlled pan/tilt tracking mounts and continues to lead the field in innovation, applied design, and service. Our patented pant/tilt units are in use in a wide range of industries including security and surveillance, industrial automation, robotics, communications, military/aerospace, law enforcement, education, R&D, webcams, and teleconferencing/distance learning applications. Some of the payloads that can be precisely controlled include sensors like video cameras, thermal imagers, laser rangefinders, microwave antennas, and many more. FLIR MCS maintains engineering capabilities in mechanical design, electronics, and embedded and network software development. Find out more at www.FLIR.com/mcs.

ABOUT FLIR SYSTEMS, INC.

FLIR Systems, Inc. is the world's largest commercial infrared company with the more high quality thermal night vision systems in the field than all other manufacturers combined. Our rugged, stabilized imagers are on thousands of civil and military surface and airborne platforms in the USA and around the world.

With thousands of our thermal cameras on the job in military, scientific, law enforcement, and security applications, FLIR brings an unmatched level of experience and dedication to the creation of cutting edge thermal night vision systems.

We design and manufacture all of the critical technologies inside our products, including detectors, electronics, special lenses, and pan/tilt motion control systems. All of our products are proudly assembled right here in the USA.

For additional technical information, or to see a demonstration of these revolutionary thermal night vision systems, contact a FLIR representative today. You can also visit www.FLIR.com to watch product videos and see how thermal imaging can help you see night and day.

LIMITED WARRANTY

FLIR Motion Control Systems, Inc. warrants this product against defects in material or workmanship, as follows:

For a period of one year from date of purchase, FLIR Motion Control Systems, Inc. will repair the defective product and provide new or rebuilt replacements at no charge. Warranty repairs require the issuance of a repair authorization number from FLIR Motion Control Systems prior to the return of merchandise, and the buyer assumes responsibility for freight charges.

After the one year period, the purchaser must pay for all parts, labor, and freight.

This warranty does not cover any damage due to accident, misuse, abuse, or negligence. You should retain your original bill of sale as evidence of the date of purchase.

REPAIR OR REPLACEMENT AS PROVIDED UNDER THIS WARRANTY IS THE EXCLUSIVE REMEDY OF THE PURCHASER. FLIR MOTION CONTROL SYSTEMS, INC. SHALL NOT BE LIABLE FOR ANY INCIDENTAL OR CONSEQUENTIAL DAMAGES FOR BREACH OF ANY EXPRESS OR IMPLIED WARRANTY ON THIS PRODUCT, EXCEPT TO THE EXTENT PROHIBITED BY APPLICABLE LAW, ANY IMPLIED WARRANTY OF MERCHANTABILITY OR FITNESS FOR A PARTICULAR PURPOSE ON THIS PRODUCT IS LIMITED IN DURATION TO THE DURATION OF THIS WARRANTY.

Some states do not allow the exclusion or limitation of incidental or consequential damages, or allow limitations on how long an implied warranty lasts, so the above limitations or exclusion may not apply to you. This warranty gives you specific legal rights, and you may also have other rights which vary from state to state.

PTU-D47 User Manual v. 4.20 (11/2011)



Motion Control Systems

890C Cowan Road
Burlingame, CA 94010
p: (650)692-3900
f: (650)692-3930
www.FLIR.com/MCS
